

Biomedical Applications of Titanium and its Alloys

C.N. Elias, J.H.C. Lima, R. Valiev, and M.A. Meyers

Titanium alloys are considered to be the most attractive metallic materials for biomedical applications. Ti-6Al-4V has long been favored for biomedical applications. However, for permanent implant applications the alloy has a possible toxic effect resulting from released vanadium and aluminum. For this reason, vanadium- and aluminum-free alloys have been introduced for implant applications.

INTRODUCTION

Materials used for biomedical applications cover a wide spectrum and must exhibit specific properties. The most important property of materials used for fabricating implants is biocompatibility, followed by corrosion resistance. The main metallic biomaterials are stainless steels, cobalt alloy, and titanium and titanium alloys.

Stainless steel was the first metallic biomaterial used successfully as an implant. In 1932, the cobalt-based alloy named Vitallium was developed for medical applications. Titanium is the newest metallic biomaterial. In both medical and dental fields, titanium and its alloys have demonstrated success as biomedical devices.

MEDICAL APPLICATIONS AND BIOCOMPATIBILITY

Titanium alloys are now the most attractive metallic materials for biomedical applications. In medicine, they are used for implant devices replacing failed hard tissue. Examples include artificial hip joints, artificial knee joints, bone plates, screws for fracture fixation, cardiac valve prostheses, pacemakers, and artificial hearts. Ti-6Al-4V has long been a main medical titanium alloy. However, for permanent implant applications the alloy has a possible

toxic effect resulting from released vanadium and aluminum. For this reason, vanadium- and aluminum-free alloys have been introduced for implant applications, based on the Ti-6Al-4V implants. These new alloys include Ti-6Al-7Nb (ASTM F1295), Ti-13Nb-13Zr (ASTM F1713), and Ti-12Mo-6Zr (ASTM F1813).

A great number of in-vivo and in-vitro titanium experiments have been done at universities and industries throughout the world for the last 50 years. These experiments found that the excellent biocompatibility of tita-

nium is associated with its oxides. C.B. Johansson¹ demonstrated in in-vivo animal model studies that the titanium oxide may differ from metallic biomaterials such as Ti-6Al-4V, CoCr alloys, and stainless steel 316 LVM. The interface between the titanium implant and the bone is a thin proteoglycans layer.

Commercially pure titanium (Cp Ti) is considered to be the best biocompatible metallic material because its surface properties result in the spontaneous build-up of a stable and inert oxide layer. The main physical properties of titanium responsible for the biocompatibility are: low level of electronic conductivity, high corrosion resistance, thermodynamic state at physiological pH values, low ion-formation tendency in aqueous environments, and an isoelectric point of the oxide of 5–6. In addition, the passive-film-covered surface is only slightly negatively charged at physiological pH, and titanium has a dielectric constant comparable to that of water with the consequence that the Coulomb interaction of charged species is similar to that in water.

DENTISTRY APPLICATIONS

Titanium and its alloys are also used for dentistry devices such as implants, crowns, bridges, overdentures, and dental implant prosthesis components (screw and abutment). Commercially pure titanium is used preferentially for endosseous dental implant applications. There are currently four cp Ti grades and one titanium alloy specially made for dental implant applications. These metals are specified according to ASTM as grades 1 to 5. Grades 1 to 4 are unalloyed, while grade 5, with 6% aluminum and 4% vanadium, is the strongest. According to ASTM F67 and F136, the titanium bar mechanical

How would you...

...describe the overall significance of this paper?

This article enumerates some materials used for biomedical applications, emphasizing the use of commercially pure titanium for dental implants, and explains the importance of titanium chemical composition on osseointegration.

...describe this work to a materials science and engineering professional with no experience in your technical specialty?

Ultrafine grain titanium should have adequate biocompatibility and higher mechanical properties than commercially pure titanium. Dental implants were inserted in a rabbit and no statistical difference was observed between the osseointegration of cp Ti and ultrafine grain titanium.

...describe this work to a layperson?

In medicine titanium alloys are used for implant devices replacing failed hard tissue. This article compares biocompatibility properties of different biomaterials and shows that ultrafine grain titanium has adequate biocompatibility for dental implant use.

Table I. Selected Mechanical Requirements Properties of Titanium Bar for Implant*

Property	ASTM Grade				
	1	2	3	4	5
Yield Strength (MPa)	170	275	380	483	795
Ultimate Tensile Strength (MPa)	240	345	450	550	860
Elongation (%)	24	20	18	15	10
Elastic Modulus (GPa)	103–107	103–107	103–107	103–107	114–120

*Adapted from ASTM F67 (Grade 1 to 4) and F136 (Grade 5).

properties of grades 1 to 5 are summarized in Table I.

Titanium grade 1 has the highest purity, lowest strength, and best room-temperature ductility of the four ASTM titanium unalloyed grades. Grade 2 titanium is the main cp Ti used for industrial dental implant applications. The guaranteed minimum yield strength of 275 MPa for grade 2 is comparable to those of annealed austenitic stainless steels.

Titanium grade 3 has 0.30 maximum iron content, which is lower than grade 4 (0.50 maximum). Grade 4 has the highest strength of the unalloyed ASTM grades. Grade 5, an ASTM titanium alloy (Ti-6Al-4V), is the most widely used titanium alloy in medical implants but not common in dental implants. The alloy is most commonly used in the annealed state.

Titanium and Ti-6Al-4V present low shear strength and low wear resistance when used in an orthopedic prosthesis. Also important is the mismatch of Young's modulus between the titanium implant (103–120 GPa) and bone (10–30 GPa), which is unfavorable for bone healing and remodeling. Some research has been done to resolve these problems and many new titanium alloys have been developed for biomedical applications. However, there is a contradiction between the elastic modulus and other mechanical properties. When the elastic modulus is reduced, the strength of the titanium alloy is also decreased. Conversely, when the strength is enhanced, the elastic modulus is also increased.

Several studies have compared cp Ti to Ti-6Al-4V implants inserted in rabbit bones. It has been shown that when twisted, the cp Ti implant has higher removal torque values than Ti-6Al-4V screws and significantly higher bone contacts.²

DENTAL IMPLANTS

There are three types of dental implant: osseointegrated, mini-implant for orthodontic anchorage, and zygomatic. Each group needs different mechanical properties and must be made of cp Ti or a titanium alloy.

Osseointegrated Implant

The osseointegration of dental implants was initially defined by P.-I. Branemark et al.³ as a direct bone-to-implant contact and later on defined on a more functional basis as a direct bone-to-implant contact under load.

In the past, osseointegrated endosseous dental implants have been made in a variety of shapes, including hollow baskets, blades, tripods, needles, disks, truncated cones, cylinders, and screws. Currently the most commonly used dental implant has a screw shape and is made of cp Ti or Ti-6Al-4V, as shown in Figure 1. The dental implants are available with diameters from 3.3 mm to 6.0 mm and lengths from 6 mm to 16 mm.

To understand the importance of the material properties and function of an

osseointegrated dental implant, one must first be knowledgeable of the implant parts, as shown in Figure 2. Although each available implant system has a different shape, the parts are the same. The implant is the main component that actually has bone contact. To improve the biological response to titanium, different implant surface modifications have been introduced. Tissue reactions following implantation are influenced by physiochemical properties of the implant surface. Figure 3 shows an implant with good wettability surface during the surgery. The second component is the abutment, which gives the connection between the implant and the prosthesis and makes contact with soft tissue. Usually the abutment is connected to the implant with a screw, or it can be cemented. The third part of the implant structure is the prosthesis, which can be attached to the abutment with a screw or cement. The implant is made with cp Ti or a titanium alloy, the abutment with a titanium alloy, and the abutment screw with a titanium or gold alloy.

Some designs of titanium dental implants and their prosthesis components have a small diameter and thickness wall, especially with internal abutment fixation (see the last five implants in Figure 1). In these cases the implant must be made of Ti-6Al-4V to prevent fracture. However, when titanium alloys are implanted, higher levels of the component elements can be detected in tissues locally and systemically.⁴

L. Morais et al.⁴ analyzed the vanadium ion release during the implant



Figure 1. Examples of commercial dental implant designs. (Courtesy of Conexão Sistema e Prótese, Brazil.)

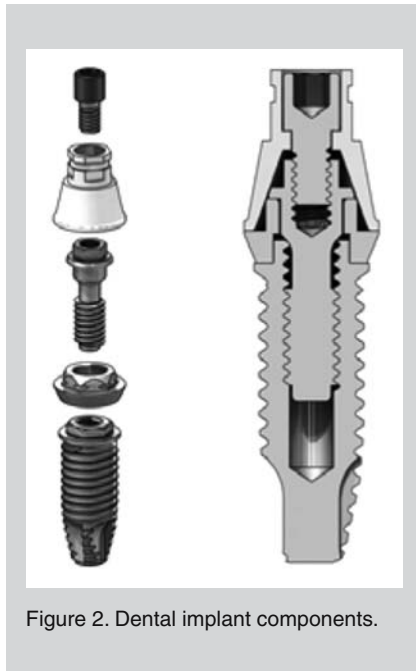

Figure 2. Dental implant components.

healing process. Titanium alloy implants were inserted in the tibiae of rabbits. After 1, 4, and 12 weeks, they were submitted to removal torque testing. The kidney, liver, and lung were extracted and analyzed by atomic absorption spectrometry. In comparison with the control values, the content of vanadium increased slightly after 1 week and significantly after 4 weeks, and decreased slightly after 12 weeks, without reaching the 1 week values.

To avoid ion release, it is necessary to develop new titanium alloy processing or increase the mechanical properties of cp Ti. One solution is nanocrystalline materials, which can offer very high strength, toughness, and fatigue resistance. Processing of nanomaterials to improve both strength and ductility is of primary importance for fatigue strength and fracture toughness. R.Z. Valiev et al.⁵ refined the microstructure of bulk billets using severe plastic deformation and increased the mechanical properties of titanium grade 2.

Ultrafine Grain Titanium in Dental Implants

As described, some dental implants made with Ti-6Al-4V can release ions to tissues locally and systemically. For stronger implants, though, alloyed titanium is preferred over unalloyed. However, biomechanically the cp Ti implants have significantly higher removal torque than the alloy implants.²

I. Semenova et al.⁶ showed that ultrafine grain cp Ti presents ultimate tensile strength as high as 1,240 MPa while retaining a ductility of 11%.

The present work analyzed the possibility of using ultrafine grain titanium in dentistry. Screw-shaped dental implants with pitch-height of 0.5 mm, outer diameter of 3.3 mm, length of 8.0 mm, a square head, and inner threaded hole of 2.0 mm were turned from titanium rods. Two types of dental implant screws were used: cp Ti ASTM grade 2 and ultrafine grain titanium grade 2.

The implants were inserted in the tibiae of New Zealand white rabbits. Bone tissue responses were evaluated by removal torque tests that were undertaken after 8 weeks. Table II shows the removal torque results. Descriptive statistical parameters were calculated and a one-way analysis of variance with Tukey's test was used to evaluate the removal torque. No statistical difference was observed between cp Ti and ultrafine grain titanium.

Table II. Dental Implant Removal Torque (N-cm) after 8 Weeks Inserted in Rabbit Tibia

	Average	Deviation
Ti ASTM Grade 2	17.0	4.2
Ultrafine Grain Ti Grade 2	18.9	1.9

Mini-Implants for Orthodontic Anchorage

Another dentistry implant is a temporary orthodontic mini-implant used generally to secure anchorage in contemporary orthodontic treatments (Figure 4). This implant has a small diameter (1.2 mm to 2.0 mm) and the orthodontic load can deform the mini-implant. Consequently, the orthodontic implants are made with Ti-6Al-4V instead of cp Ti due to the alloy's superior strength. However, the Ti-6Al-4V corrosion resistance is lower than that of cp Ti, allowing for metal ion release. This implant does not result in osseointegration.

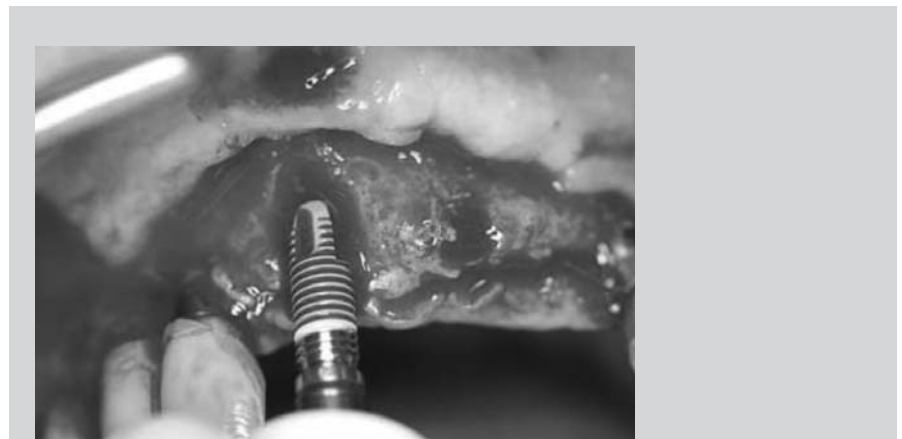

Figure 3. A dental implant with good wettability.



Figure 4. An example of an orthodontic mini-implant for anchorage application. (Courtesy of Flavia Rabello.)



Figure 5. A zygomatic implant. (Courtesy of P. Saad.)

Morais et al.⁴ inserted mini-implant orthodontics in two groups of rabbits. One group was loaded immediately after the surgery and the second group was not loaded during the healing time. When a stress analysis on the mini-implant was carried out, the torque at which cp Ti and Ti-6Al-4V deform plastically and the shear strength of the interface mini-implant-bone was calculated. No increase was observed in the removal torque value between 1 and 4 weeks of healing, regardless of the load. Nevertheless, after 12 weeks, a significant improvement was observed in both groups, with the highest removal torque value for the unloaded group. The stress analysis reveals that the removal torques for cp Ti dangerously approach its yield stress. The results of this rabbit model study indicate that titanium alloy mini-implants can be loaded immediately with no compromise in their stability. The detected concentration of vanadium did not reach toxic levels in the animal model. Consequently, to improve the mini-implant orthodontic for anchorage behavior it is important to

increase the titanium alloy mechanical properties or use cp Ti with ultra-fine grains.

Zygomatic Fixture

The third dentistry implant group is the zygomatic implants, which are made of cp Ti (Figure 5).

There are some technical approaches to the treatment of the atrophic maxilla involving a series of clinical considerations and producing different results. The development of the zygomatic implant (Nobel Biocare, Göteborg, Sweden) represents an excellent alternative for these situations. The zygomatic implant developed by P.-I. Brånemark⁷ has been used as posterior anchorage for implant-supported prostheses in patients with atrophic maxillae since 1990. It was initially conceived as a treatment for the victims of traumas or tumor resection where there was considerable loss of maxillary structure. Following maxillectomy, many patients retain anchorage regions only in the body of the zygoma or in the frontal extension of the zygomatic bone. Con-

sequently, a modification to the form of the implants is necessary, making the implants longer than conventional dental implants. Normally, the zygomatic implant has a diameter equal to 4–5 mm and 30–53 mm length. It penetrates the maxilla at the second premolar region as close to the alveolar crest as possible.⁸

References

1. C.B. Johansson, "On Tissue Reactions to Metal Implants" (PhD thesis, Dept. of Biomaterials/Handicap Research, University of Göteborg, Sweden, 1991).
2. C.B. Johansson et al., "Quantitative Comparison of Machined Commercially Pure Ti and Ti-6Al-4V Implant in Rabbit," *J. Oral Maxillofac. Implants*, 13 (1998), p. 315.
3. P.-I. Brånemark et al., "Osseointegrated Titanium Fixtures in the Treatment of Edentulousness," *Biomaterials*, 4 (1983), pp. 25–28.
4. Liliane S. Morais et al., "Titanium Alloy Mini-Implants for Orthodontic Anchorage: Immediate Loading and Metal Ion Release," *Acta Biomaterialia*, 3 (3) (2007), pp. 331–339.
5. R.Z. Valiev, R.K. Islamgaliev, and I.V. Alexandrov, "Bulk Nanostructured Materials from Severe Plastic Deformation," *Prog. Mater. Sci.*, 45 (2000), p. 103.
6. I. Semenova et al., "Superplasticity in Ultrafine-Grained Titanium: Observations and Properties Studies" (Presentation at the Structural Materials Division Symposium: Mechanical Behavior of Nanostructured Materials, in Honor of Carl Koch: Poster Session: Mechanical Properties of Nanostructured Materials, TMS 2007 Annual Meeting & Exhibition, Orlando, FL, February 25–March 1, 2007).
7. S.M. Parel et al., "Remote Implant Anchorage for the Rehabilitation of Maxillary Defects," *J. Prosthet. Dent.*, 86 (2001), p. 377.
8. L.R. Duarte et al., "The Establishment of a Protocol for the Total Rehabilitation of Atrophic Maxillae Employing Four Zygomatic Fixtures in an Immediate Loading System—A 30-Month Clinical and Radiographic Follow-Up," *Clinical Implant Dentistry and Related Research*, 9 (4) (2007), p. 186.

C.N. Elias and J.H.C. Lima are with the Biomaterials Laboratory, Instituto Militar de Engenharia, Rio de Janeiro, Brazil. **R. Valiev** is with UFA State Aviation Technical University, Ufa, Russia. **M.A. Meyers** is with the Department of Mechanical and Aerospace Engineering, University of California at San Diego, San Diego, California. Dr. Elias can be reached at elias@ime.eb.br.